

Specifications

Ethernet

Speed: 10/100Mbps
Protocols: HTTP, FTP, SMTP, SNMP, Telnet

Modbus RS485 / RS232

Two serial bus connections are available for the connection of RS485 or RS232 Modbus devices.

Mode RS485: 2-wire, half-duplex, un-terminated
Baud: selectable up to 115200 bps
Connector: 3-way, 5.08mm pitch, 2.5mm² CSA

Mode RS232: 3-wire, full-duplex
Baud: selectable up to 115200 bps
Connector: RJ45 Bus port

Diagnostics – COMMS port - RS232

A serial terminal is available for low-level configuration and diagnostic purposes. This is not usually needed but can be used in case of problems with the Ethernet connection, for example, unknown IP address.

Baud: fixed at 115200
Mode: 8 None 1, hardware handshake
Connector: 9-way female D-type
Cable: null modem

Default Settings

IP Address: 192.168.1.254
IP Address: 255.255.255.0
Gateway: 192.168.1.1
Primary DNS: 0.0.0.0
Secondary DNS: 0.0.0.0
Use DHCP: No
Log Interval: 30 minutes
Send Interval: 30 minutes
Username: root
Password: password

Mechanical

Dimensions: 157mm x 86mm x 58mm
Weight: 0.5Kg
Mounting: symmetrical DIN rail
Connectors: 5.08mm pitch, 2.5mm² CSA

Electrical

Power Supply: 12-24Vac/dc $\pm 10\%$
Consumption: <5W (typical)
Fuse: 500mA resettable (internal)

Input/Output Connections

Digital Inputs 8 x 50 volt-free contact
or open collector
Digital Outputs 2 x change-over relays
Analogue Inputs* 8 x 0-10Vdc (non-isolated)

*The analogue inputs are optimised for use with the LEM AT-B10 range of AC Current transducers

Note: The analogue outputs are not available for customer use in the DS800

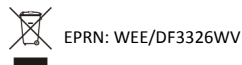

Synetica Ltd
Hilton House
40 High Street
Stone, Staffordshire
ST15 8AU
United Kingdom
Tel: 01785 818919
www.synetica.net



DataStream DS800 Data Logger Installation Guide



The DataStream is an Internet connected device for the collection, storage and transmission of meter data for energy management and environmental monitoring.

Powered by a high speed ARM[®] processor the DataStream has the capacity to acquire, process, record, present and stream data from multiple energy meters, sensors and networked devices.

The DataStream has meter pulse inputs for direct connection to energy meters and analogue inputs for use with the LEM range of AC Current Transformers.

The Modbus serial port enables communication with additional meters, Building Management Systems, PLCs and other networkable devices. TCP Modbus devices can also be read using the Ethernet network connection.

Energy consumption is recorded at selectable intervals, typically ½ hourly. This data is stored on the DataStream and automatically sent to a central server, such as the **enVision** energy dashboard software or a spread sheet such as Microsoft[®] Excel[®] for further analysis.

Installation Procedure

- Using a standard Ethernet cable (RJ45 plugs), connect the DataStream to the Ethernet network.
- Connect the field devices to the DataStream IO terminals, such as a Modbus network or pulse meters, as described in the *Field Connections* section.
- Connect a suitable power supply to the V_{in} terminals.
- Check the following:
 - * The green Power LED illuminates, indicating the power supply is connected
 - * The Input LEDs perform a start-up routine indicating the DataStream processor is initialising, after which they will remain off
 - * The Status LED flashes periodically to indicate the DataStream is operational
- Configure the DataStream, as described in the *DataStream Configuration Guide* available via a secure link from our website at www.synetica.net/datastream.html using logon credentials:

UID: **datastream**
PWD: **datastream**

Each time a pulse is detected at a digital input, the corresponding Input LED will flash.

The Modbus network should be connected according to the remote device manufacturer's guidelines. The COM terminal at the DataStream is not internally connected and is only intended to facilitate the connection of a suitable ground to the network cable shield. No termination resistor is installed in the DataStream.

Field Connections

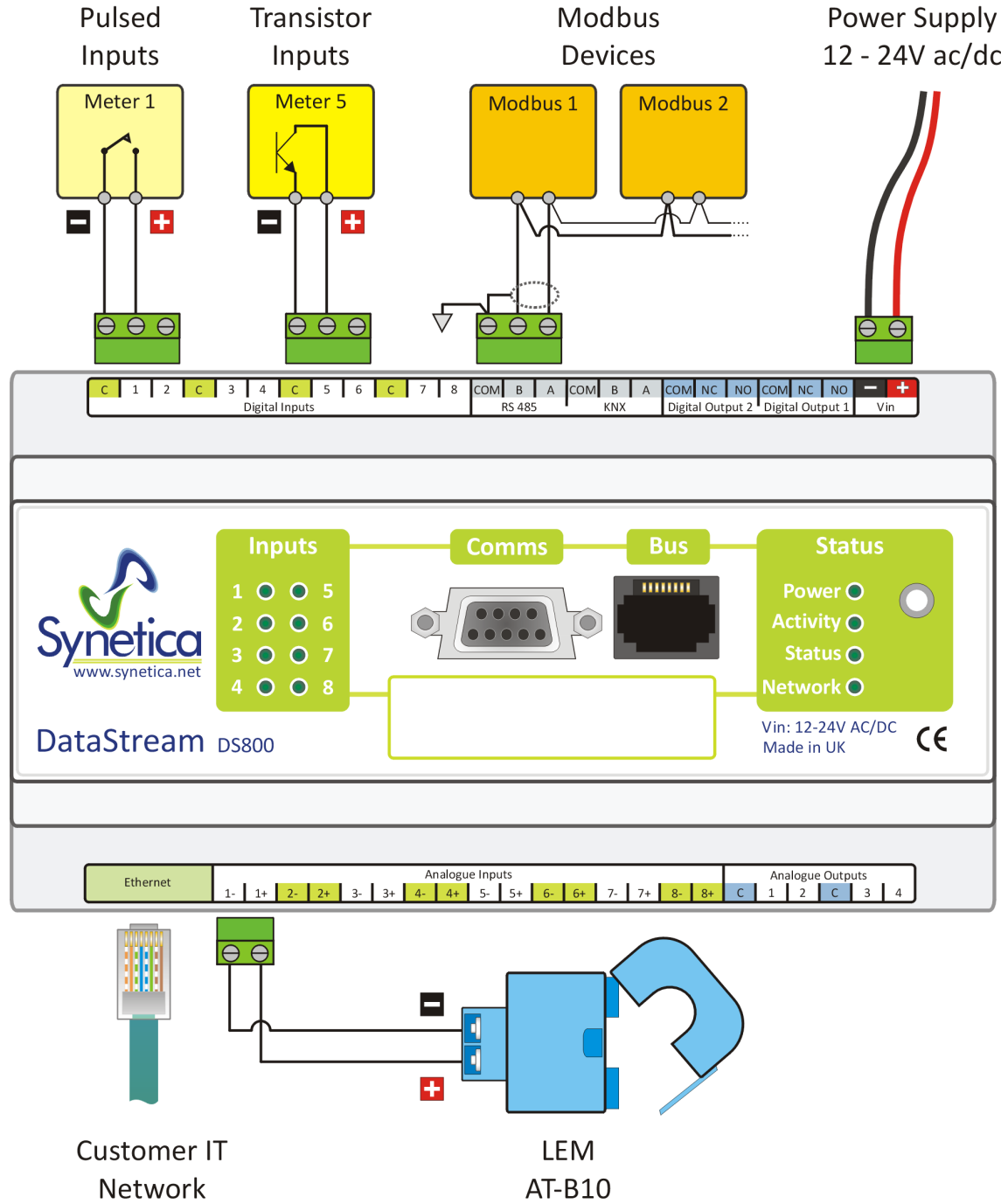

LEM Gateway Wireless Receiver

