



enLink [📶]Status-AF

USER GUIDE

LoRaWAN Air Velocity Sensor



Contents

enLink Status-AF User Guide

| | |
|---|-----------|
| 1. Introduction | 4 |
| 2. Configuration | 4 |
| 3. Powering the Unit | 5 |
| 4. Setting / Changing the LoRaWAN Keys and Device Parameters | 6 |
| 5. Setting / changing the transmit interval | 9 |
| 6. Setting / changing the pressure sensor parameters | 9 |
| 7. Zeroing air velocity readings | 11 |
| 8. Live Display | 12 |
| 9. Sensor Installation | 12 |
| 10. Differential Pressure / Air Filter Monitoring | 13 |
| 11. Air Velocity Monitoring | 14 |
| 12. Battery Installation / Replacement | 16 |
| 13. Power Considerations | 17 |
| 14. LoRaWAN Payload Decoder | 17 |
| 15. Technical Support | 17 |

enLink Status AF

LoRaWAN Air Velocity Sensor

Synetica's enLink Status-AF, LoRaWAN Air Velocity Sensor measures air velocity with industry leading accuracy ensuring air flow rates for HVAC are monitored at all times.

The system is also suitable for areas where the need to monitor air flow is paramount such as hospital operating rooms and laboratory, industry and pharmaceutical clean rooms.

The enLink Status-AF transmits data using long range LoRa wireless which easily integrates with cloud services or on-site systems via Modbus IP to ensure users are kept up to date with operational performance and to generate alerts when necessary.



enLink Status-AF:

- Supplied with air velocity probe 100mm to 600mm
- Air velocity range 0 -40m/s
- Simple, quick installation
- Easy configuration via USB / downlink
- LoRa™ wireless, up to 16km range
- Built in USB port for power and configuration
- Battery life 3+ years*
- Signal and battery indicator
- Made in the UK

*Battery life depends on configuration, data rate and environment

Features

- Range: 0 to 40m/s
- Long-term stability $\pm 0.1\%$ FSS
- Exceptional zero stability
- Selectable bandwidth filter
- Up to 7 calibrated ranges with automatic ranging
- Frequency Range 863-870MHz**
- Frequency Range 902-928MHz**
- Accuracy: 0.1% per range
- Up to +16dBm Tx Power
- Integrated 50/60Hz filter
- Temperature compensated
- UKCA, RoHS, CE, FCC compliant
- Dimensions: 129mm x 67mm x 41mm
- Enclosure IP rating: Standard IP40 / NEMA 1
- With optional gasket IP67 / NEMA 4

**Option / model dependent

1. Introduction

enLink Status-AF measures air velocity in the range of 0 to 40m/s with industry leading accuracy of 0.1%. This sensor can be used to ensure that recommended air flow rates for public buildings and industrial plant are achieved. Air velocity data is transmitted using long range LoRa wireless for integration with cloud services or onsite systems via Modbus IP to reveal operational performance and generate alerts.

The units are battery powered with long life of 3+ years#.

A built in USB port allows all parameters including pressure ranges, sampling interval, wireless signal strength and wireless network configuration to be viewed and set using simple menus via any USB enabled host such as a PC or Mac.

2. Configuration

LoRa devices can be configured using OTAA (Over-the-Air-Activation) or ABP (Activation-by-Personalisation).

OTAA is the most secure way to connect a device to the LoRa network. In OTAA, the device performs a join procedure with the network, during which a dynamic DevAddr (device address) is assigned and security keys are negotiated with the device.

ABP allows you to set the DevAddr as well as the security keys in the module. This is simpler than OTAA as there is no join procedure, however, it is less secure than OTAA.

This guide will illustrate using OTAA as it is the most secure and flexible method.

The OTAA configuration requires the following parameters to be correctly set.

- DevEUI: End-device Identifier. It is unique for every device and is set at device manufacture.
- AppEUI / JoinEUI*: Application Identifier. Used to identify the end application.
- AppKey: Application key. Used to create the session keys.

**Note: In LoRaWAN 1.1, AppEUI was renamed to JoinEUI.*

For many applications Synetica can supply enLink Status-AF units with the above parameters pre-configured, so providing the LoRa gateway has the matching keys the join process will happen automatically once the enLink Status-AF unit is in wireless range and switched on.

The DevEUI is always set at device manufacture and is unique. The device AppEUI and AppKey can easily be set via the USB connection if required and the process is detailed later in this document.

3. Powering the Unit

To power the device ON, remove the cover of the enLink Status by unscrewing the two screws on the cover. Locate the power switch, shown below and using small screwdriver gently slide the power switch towards the Off position.

Insert the 2 x AA sized Lithium 3.6V batteries taking great care to insert them the correct way around. Locate the plus (+) and minus (-) signs on the battery and use the plus (+) and minus (-) guides on AA battery holders to insert the batteries in the proper direction. Both batteries face in the same direction.

Be sure to insert the minus (-) end first and remove the plus (+) end first when replacing the batteries.



Lithium batteries have very high energy capacity and a great degree of care should be exercised to ensure that all batteries are new, from the same manufacturer, installed the correct way around and are not in any way damaged. Refer to Section 12 for more details.

Check that the batteries are correctly inserted and then slide the power switch to on.

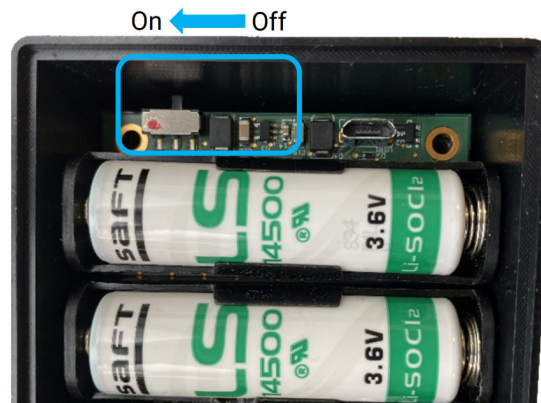

Switch to the On Position

Once powered ON, the enLink device will send a Join request message to the LoRaWAN network server. The Status LED will blink RED as shown below whilst the Join process is taking place. Depending on factors such as signal strength, RF interference etc. the join process may take several seconds to complete.



Blinking Red LED - Attempting to Join

When the device has successfully joined the network the Mode LED will blink GREEN five times to show that the join has been completed. The LED's will then switch off to conserve the batteries.



Blinking Green LED - Device Successfully Joined

4. Setting / Changing the LoRaWAN Keys and Device Parameters

The unique DevEUI is printed on all enLink devices and is also present in the QR code. The DevEUI can be used to identify the device once joined to the network.

For many applications, Synetica can supply enLink units with the LoRaWAN AppEUI and AppKey parameters preconfigured to your requirements, whereby if the LoRa gateway has matching keys the join process will happen automatically once the unit is in wireless range and switched on.

The DevEUI is always set at device manufacture and is unique. The device AppEUI and AppKey can easily be set via the USB connection as detailed below.

Connect a micro USB cable to the enLink unit. The device will attach to a COM port on your PC.

Using a terminal program (e.g. Tera Term <https://github.com/TeraTermProject/teraterm/releases>) connect to the COM port used by the enLink device. See Synetica document "Configuring enLink Devices Using Serial Terminal Applications" for more details including using PuTTY and serial applications that will operate on Apple and Linux computers

To verify which COM port is being used, check the Windows™ **Device Manager** (In Windows - Click the Start button, type **Device Manager** into the search box and tap **Device Manager** on the menu.) Expand the **Ports (Com & LPT)** menu as shown below.

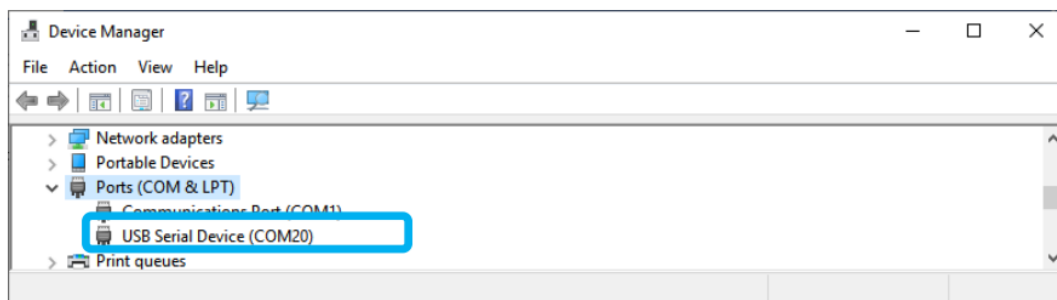

In your terminal program press the Enter key. An enLink summary screen will appear as shown below. The default password is the last four digits of the displayed DevEUI, in the screen below this is c299.

```

-----
Synetica - enlink :: Wireless Sensor Networks
-----
Region:           European band on 868MHz
Firmware Code:   FW-ST5-DP/AF
Firmware Ver:    6.14
Description:     enLink Status - Differential Pressure / Air Flow
DevEui:          00-04-a3-0b-01-2d-c2-99
-----

Password: █
  
```

enLink Logon Screen

The screen below will show with the enLink Main Menu options. Enter **Q** to enter the Quick Start Menu.

```

COM5 - Tera Term VT
File Edit Setup Control Window Help

enlink Main Menu:
=====
Q - Quick Start Menu
L - LoRa Radio Settings
C - Configure Device
P - Password and Security
T - Test Mode
R - Reboot
F - Factory Reset
X - Log off

Select an option:
  
```

enLink Main Menu

The Quick Start Menu contains only the parameters that normally need to be configured to setup the device and join the LoRa network. From the Quick Start Menu you can change the AppEUI and AppKey.

```

COM5 - Tera Term VT
File Edit Setup Control Window Help

enlink Quick Start Menu:
=====
Status                               Joining...
Join Check in                          0s

DevEui                                00-04-a3-0b-00-08-2f-a5
E - AppEui                            53-79-6e-00-00-00-00-00
K - AppKey                             08-34-5e-d2-a4-a1-5a-1e-00-cd-16-2a-1b-b9-91-f7
T - Transmit Interval                  30 mins
X - Exit Menu

Select an option:
  
```

Quick Start Settings Menu

From the Quick Start Settings Menu, access the AppEUI setting by entering **E**. Enter the 16 character AppEUI using numbers and letters A to F. Do not include spaces or any other characters. Pressing **S** will enter the default AppEUI which you can then edit. Press Enter when the key is correctly entered to return to the Quick Start Settings Menu.

```

E - AppEui                            53-79-6e-00-00-00-00-00
K - AppKey                             e6-ba-6c-c9-61-87-47-75-9d-13-e4-e0-9a-5f-40-0d
T - Transmit Interval                  15 mins
X - Exit Menu

Select an option: e

Enter a new 16 character AppEUI using only numbers and the letters A to F (no separators)
Hit <S> to enter the default value or <R> for a random value

Current Setting: AppEUI = 53-79-6e-00-00-00-00-00

-----
New AppEUI: 53796e0000000000
  
```

AppEUI Setting

From the Quick Start Settings Menu access the AppKey setting by entering **K**. Enter the 32 character Appkey using numbers and letters A to F. Do not include spaces or any other characters. Pressing **S** will enter the default AppKey which you can then edit. Press Enter when the key is correctly entered to return to the Quick Start Settings Menu.

```

E - AppEui                53-79-6e-00-00-00-00-00
K - AppKey                e6-ba-6c-c9-61-87-47-75-9d-13-e4-e0-9a-5f-40-0d
T - Transmit Interval    15 mins
X - Exit Menu

Select an option: k

Enter a new 32 character AppKey using only numbers and the letters A to F (no separators)
Hit <S> to enter the default value or <R> for a random value

Current Setting: AppKey = e6-ba-6c-c9-61-87-47-75-9d-13-e4-e0-9a-5f-40-0d

-----
New AppKey: █

```

AppKey Setting

Press **X** from the Quick Start Settings Menu to return to the enLink Main Menu.

The header will show **** Reboot Required **** as shown below. The new key settings will not take effect until the enLink device is restarted. Enter **R** to reboot followed by **OK**. The device will restart with the entered AppEUI and AppKey and attempt to join the LoRa network.

```

enLink Main Menu:  ** Reboot Required **
=====
Q - Quick Start Menu
L - LoRa Radio Settings
C - Configure Device
P - Password and Security
T - Test Mode
R - Reboot
X - Exit and log off

Enter Selection: █

```

Reboot Required Notification

5. Setting / changing the transmit interval

Access the Transmit Interval setting by entering **T** from the quick start menu.

```

Transmit Interval:  ** Reboot Required **
=====
 1 - 30 s
 2 - 1 min <==
 3 - 2 mins
 4 - 5 mins
 5 - 10 mins
 6 - 15 mins
 7 - 20 mins
 8 - 30 mins
 9 - 60 mins
10 - 2 hours
11 - 3 hours
Enter Selection: █

```

Transmit Interval Settings

Select a fixed transmit interval from the menu options. 15 minutes or longer is recommended to extend battery life.

Press Enter when the key is correctly entered to return to the Quick Start Settings Menu.

The Transmission Interval may also be changed by using a LoRaWAN downlink message. See "<https://github.com/synetica/enlink-decoder?tab=readme-ov-file#downlink-message-index-tables>" for more details and example downlink messages.

6. Setting / changing the pressure sensor parameters

The pressure sensor parameters can be offset to compensate for pipe lengths, environmental conditions and sensor drift. Where possible, the zeroing adjustment should be carried out when the sensor is in its measurement position and environment.

From the Main Menu access the configuration menu by entering **C**. This screen will display the current device temperature, humidity, pressure sensor values and also provide access to live readings.

```

Sensor Readings:
-----
-- Differential Pressure / Air Flow Sensor
  Temperature          25.3°C
  Raw Read             23.561 Pa
  Delta Offset Zero Fix 0.000 Pa
  Pressure             23.561 Pa
  Air Flow             6.266 m/s

Device Options:
-----
D - Live readings display
P - Differential Pressure / Air Flow
X - Exit Menu
Select an option: █

```

Configuration Menu

Enter **P** to view the Differential Pressure / Air Flow menu

```
Select an option: p

DP/AF options:
=====
T - Radio Transmit Options          Both Pressure and Air flow
Z - Zero reading (auto delta)
D - Set Delta Offset                -23.322 Pa
X - Exit Menu

Select an option:
```

Enter **Z** to enter the Zero reading (auto delta) menu. The required offset value will be shown. Enter **Z** to zero the measurement.

```
DP/AF options:
=====
T - Radio Transmit Options          Both Pressure and Air flow
Z - Zero reading (auto delta)
D - Set Delta Offset                -23.329 Pa
X - Exit Menu

Select an option: z

Hit <Z> to offset the value by the last raw reading of '23.329 Pa': z

Delta Offset set to: -23.329 Pa

Press a key to continue:
```

To manually enter an offset, press **D** to enter the Set Delta Offset menu. The offset value is used to adjust the measurement. Negative or positive values can be entered to adjust the reading.

Enter **X** to return to the Options menu.

The unit can be configured to transmit Air Flow, Differential Pressure, or both readings.

Enter **T** to access the Radio Transmit Options menu and select the transmission of Pressure data only, Airflow data only or both.

```
Select an option: t

DP/AF -> Radio Transmit Options:
=====
0 - Pressure Only
1 - Air flow Only
2 - Both Pressure and Air flow      <==
X - Exit Menu

Select an option: |
```

Radio Transmit Options

7. Zeroing air velocity readings

On enLink Status-DP/AF units with Firmware release v5.14 and later, the differential pressure / air velocity reading can also be set to Zero by pressing the Config button on the front of the unit.

To automatically zero the differential pressure reading, press and hold the Config button for more than two seconds. The Red and Green LED's will flash rapidly as the unit measures the differential pressure. Once the differential pressure offset has been applied the Green Mode LED will blink several times to confirm that the operation is complete.

The differential pressure reading may also be automatically Zeroed with a LoRaWAN Downlink message.

The downlink message to send is: A5 01 40

See <https://github.com/synetica/enlink-decoder?tab=readme-ov-file#differential-pressure-air-flow-downlinks> for more details.

8. Live Display

From the Main Menu access the configuration menu by entering **C**. This screen will display the current device temperature and pressure sensor values and also provide access to live readings.

```

Sensor Readings:
-----
-- Differential Pressure / Air Flow Sensor
  Temperature          25.3°C
  Raw Read             23.561 Pa
  Delta Offset Zero Fix 0.000 Pa
  Pressure             23.561 Pa
  Air Flow             6.266 m/s

Device Options:
-----
D - Live readings display
P - Differential Pressure / Air Flow
X - Exit Menu

Select an option: █

```

Configuration Menu

The **D** option displays live readings, which can be used to verify the readings before deployment.

| enLink Status - Differential Pressure / Air Flow - FW-ST5-DP/AF V.7.09 | |
|--|---|
| LoRa Info | Uptime: 18s LoRa: Joining... Join Check in: 0s |
| CPU: 31.4°C | Joining... |
| DP/AF Sensor » | Model: HV120 Temperature: 25.9°C Raw Read: 23.825 Pa Delta Fix: 0.000 Pa |
| | Serial: 8309B105 SW Ver: 0003D Inches H20: 0.0956 Auto Range: 2.5 inH20 |
| Readings: | Pressure: 23.825 Pa Air Flow: 6.302 m/s |

Press a key to exit

Live Readings Display

9. Sensor Installation

Depending on the probes used, the enLink Status unit can be used as either a differential pressure monitor or as an airflow monitor.

10. Differential Pressure / Air Filter Monitoring

When a filter starts to clog, its resistance to airflow increases. In systems where the airflow is kept at a constant level, this leads to a rise in the differential pressure across the filter.

Air filters can only perform well when the pores remain unclogged. Filters should be replaced when they begin to clog to ensure economical, safe and efficient operation. Clogged filters can lead to an under-supply of ventilation, an increase in energy consumption, and noisy fan operation. Filters which are dirty and humid can provide a breeding ground for mould and bacteria, damaged filters can be hazardous.

To monitor the filter condition, attach one of the supplied pitot probes to either side of the filter as shown below. Ensure that the port on the Status unit shown as + goes on the airflow input to the filter and the port shown as – on the downstream side of the filter.

With the fan in the off state, the differential pressure should be close to zero. If necessary, offset the pressure reading to as close to zero as possible using the instructions in section 6/7.

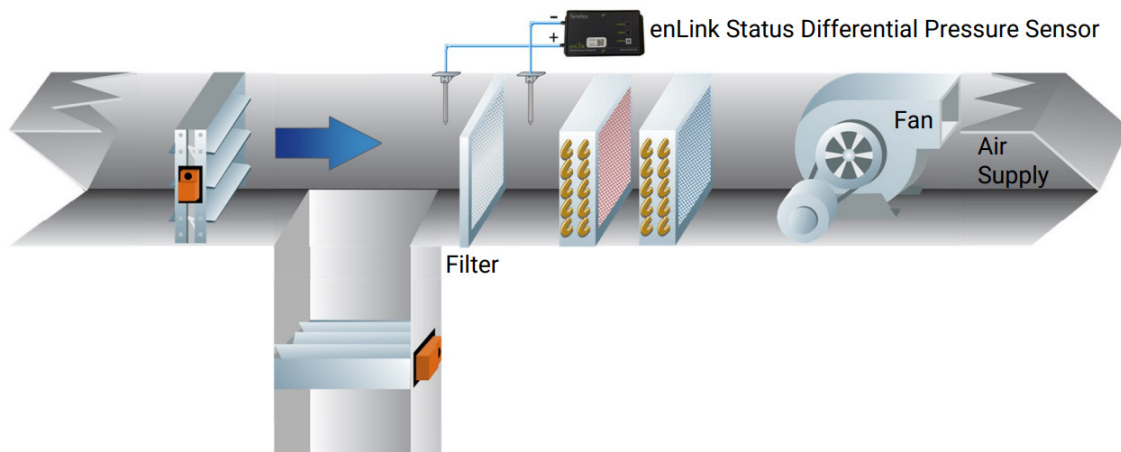

Differential Pressure Sensor to Monitor Filter Condition

11. Air Velocity Monitoring

Measuring the air velocity in ducts is an important maintenance aspect of an HVAC system. Each system is designed to work under a given load. Lower loads can lead to an underperforming system and higher loads can result in reduced efficiency and increased running costs.

To monitor the airflow, insert the airflow probe into the duct as shown below.

- The airflow probe should be installed in a section of duct where it can measure stable, unrestricted airflow. Position it at least 2 m downstream from dampers, bends, fans, filters, humidifiers, and heating or cooling coils to avoid turbulence. As a rule of thumb:
 - Provide at least 8–10 duct diameters of straight run upstream of the probe.
 - Provide at least 2–3 duct diameters of straight run downstream.
- Ensure that the two end probe caps are fitted and not loose.
- Ensure that the probe is mounted with all the holes inside the ductwork and that the mounting flange is providing a good airtight seal.
- Ensure that the probe is mounted with the arrow pointing in the direction of the airflow.
- Ensure that the tube connections for the Hi and Lo ports are matched on the Status Unit.
- Secure the pipes to the probe with cable ties if necessary.
- Probe insertion depth:
 - A probe should reach at least the centerline of the duct (halfway in).
 - For highest accuracy (averaging pitot probes), a full-length probe that spans the duct diameter is ideal, since it allows multi-point measurement across the cross-section.
- Rule of thumb:
 - Small ducts (<300 mm / 12 in): probes often span the full diameter.
 - Larger ducts: probes may be available in standard lengths (e.g., 100, 200, 300, 500 mm) and should be long enough to reach the duct center.

With the fan in the off state the airflow should be close to zero. If necessary, offset the sensor pressure reading to as close to zero as possible using the instructions in section 6/7.

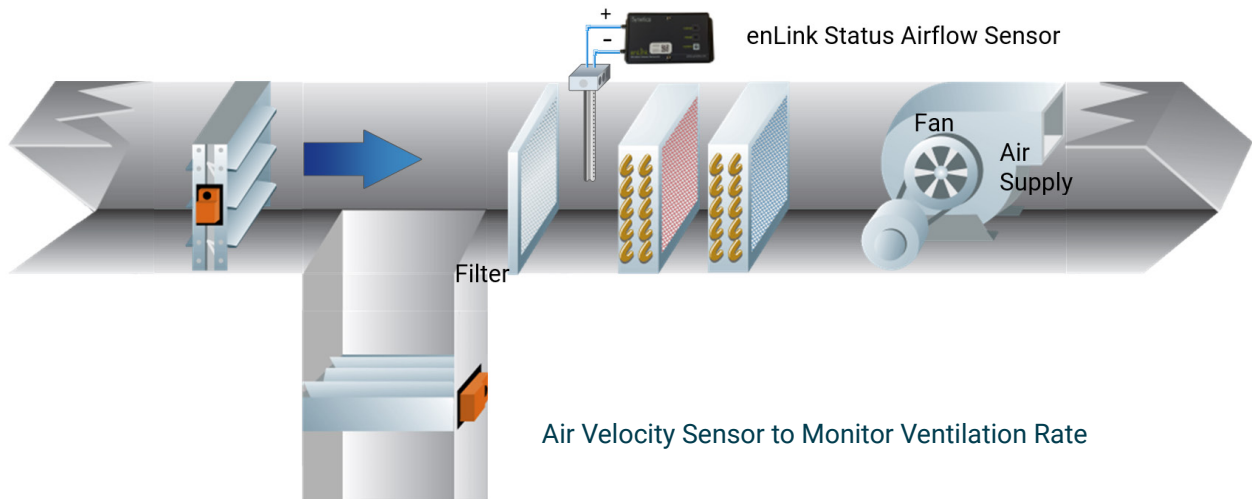
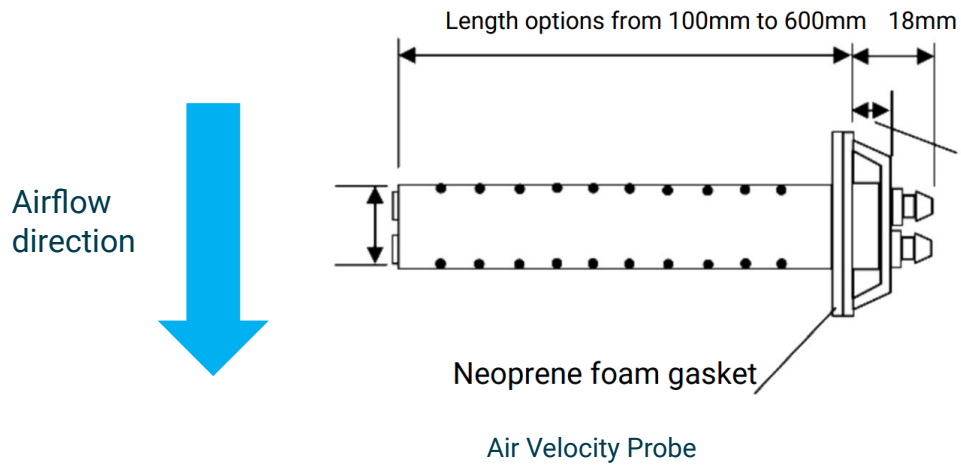

12. Battery Installation / Replacement

enLink devices use SAFT LS14500 or EVE ER14505 AA size 3.6 Volt Lithium Thionyl Chloride (Li-SOCl₂) batteries (non-rechargeable) or direct equivalent.

No other batteries are approved for use in the device.

Lithium Thionyl Chloride batteries have very high energy capacity and must be used and handled with care observing the guidance below.

WARNING! Risk of death or serious injury from explosion or fire



- Keep out of sight and reach of children.
- Fire, explosion and burn hazard - do not recharge, short circuit, crush, disassemble, incinerate.
- Due to the high terminal voltage (3.6V), they are not suitable as direct replacements for other battery technologies in the same can sizes.
- When not in use the Batteries must be stored in a non-hazardous area.
- Do not change batteries in an explosive gas atmosphere.
- When installing batteries, do not snag the battery terminal on the clip or the battery may be damaged. Do not apply excessive force.
- Do not drop. Dropping the battery may cause damage. If a battery is dropped, do not install the dropped battery into the unit
- Dispose of dropped battery promptly per local regulations or per the battery manufacturer's recommendations.

GUIDANCE

- Always install the batteries correctly as per instructions taking great care to observe the battery polarity.
- Ensure that the contact points are clean and conductive.
- All batteries must be the same model from the same manufacturer.
- Do not mix old and new batteries or batteries from different manufacturers.
- Do not heat or attempt to recharge the battery.
- Do not dispose of in a fire.
- Only install approved batteries: SAFT LS14500 or EVE ER14505 Lithium-thionyl chloride AA battery 3.6 volt, or direct equivalent.

SAFE DISPOSAL



- Please recycle responsibly, a wide range of schemes are available.
- Do not dispose of in normal waste or in a fire.

13. Power Considerations

The device is powered with 2 x 3.6V Lithium-Thionyl chloride (Li-SOCl₂) AA sized batteries.

The pressure sensor consumes additional power while actively sensing and therefore, to prolong battery life, the sampling interval should be set to the longest period practical for the application. Sampling / transmission intervals of less than 15 minutes place strain on the batteries, limiting their capacity and should be avoided if possible.

Battery capacity is dependent on ambient temperatures and this should be considered when estimating battery life. Low temperatures slow down electrochemical reactions significantly and increase the internal resistance of the batteries. High temperatures increase the battery self-discharge. The chart below illustrates the effect of temperature on the available battery capacity.

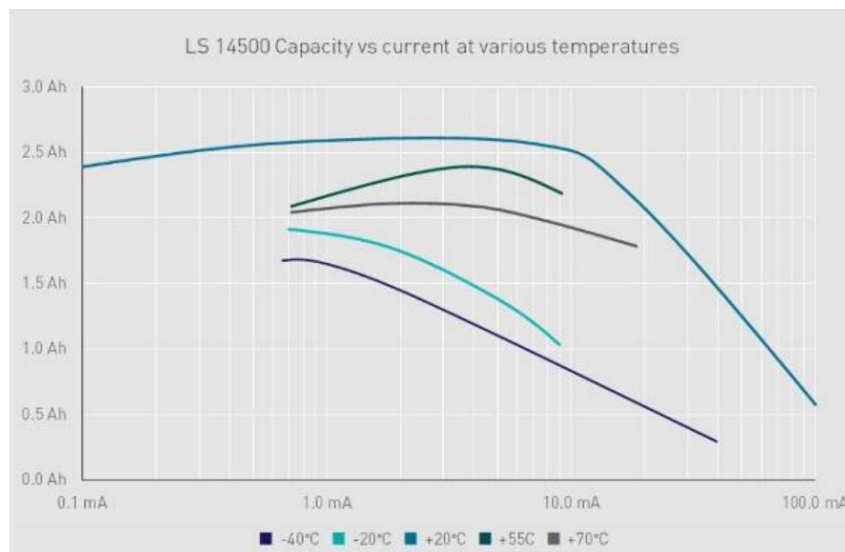

Battery Capacity vs Current at Various Temperatures for SAFT LS14500 Batteries

Battery life is also highly dependent on the LoRa spreading factor used. Higher spreading factors result in longer active times for the radio transceivers and shorter battery life. Positioning devices in closer proximity to a gateway will generally result in lower spreading factors, shorter time on air and much lower transmit power.

14. LoRaWAN Payload Decoder

The latest LoRaWAN payload decoders and guides are available on the Synetica GitHub repository:

<https://github.com/synetica/enlink-decoder>

A live payload decoder which allows you to paste LoRa payloads in Hexadecimal or Base 64 and see the correctly decoded results can be found at the link below:

<https://synetica.github.io/enlink-decoder/>

15. Technical Support

For technical assistance, please visit the downloads section of our web site at www.synetica.net or email us at support@synetica.net

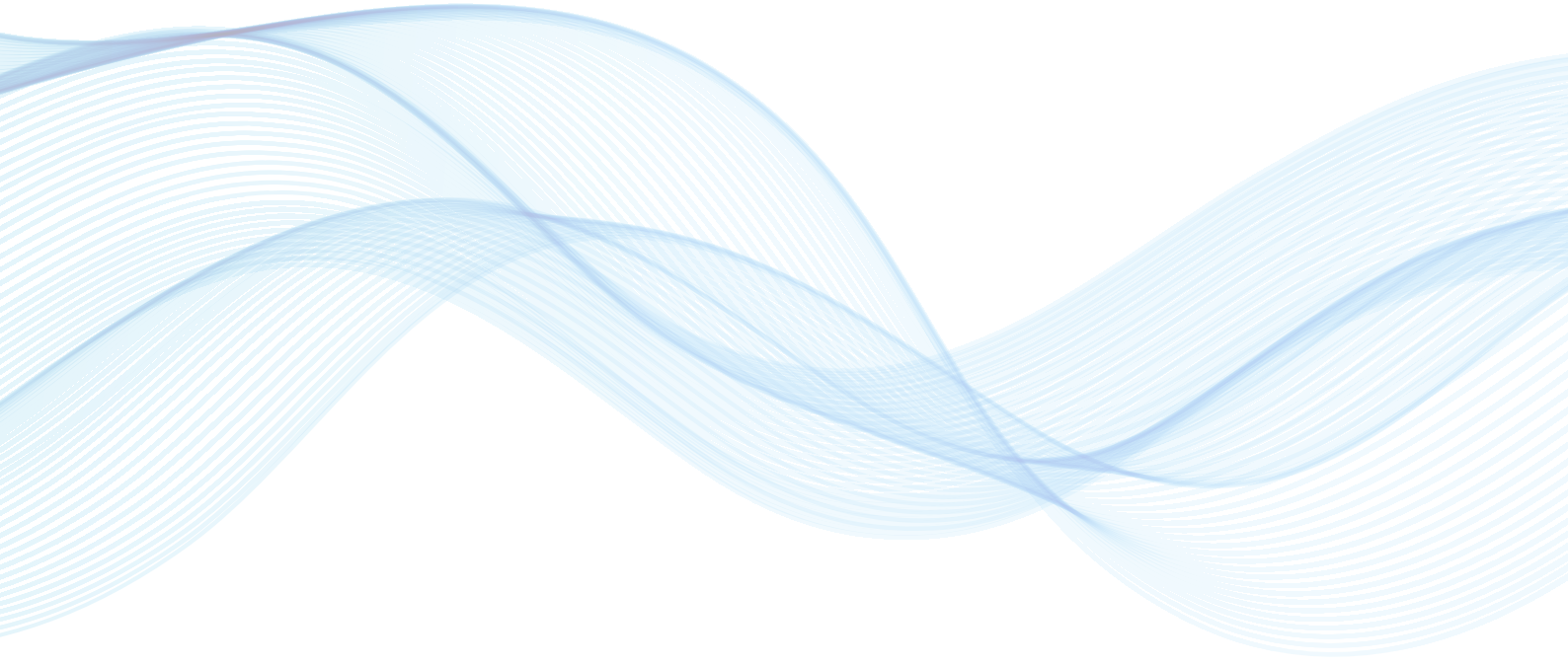

About us

Synetica was established in 2008 with the simple idea to revolutionise air quality monitoring, energy usage and remote asset monitoring. Our global customer base relies on our expertise to help them reduce emissions and clean up the air they breathe by allowing them to monitor their energy usage and key environmental parameters via the touch of a button.

www.synetica.net

T: +44 (0)1785 818919 **E:** enlink@synetica.net

Synetica Limited, Hilton House, 40 High Street, Stone, Staffordshire. ST15 8AU UK

